

Installation, Operation and Maintenance Manual

Please read and save these instructions for future reference. Read carefully before attempting to assemble, install, operate or maintain the product described. Protect yourself and others by observing all safety information. Failure to comply with these instructions will result in voiding of the product warranty and may result in personal injury and/or property damage.

Figure 1

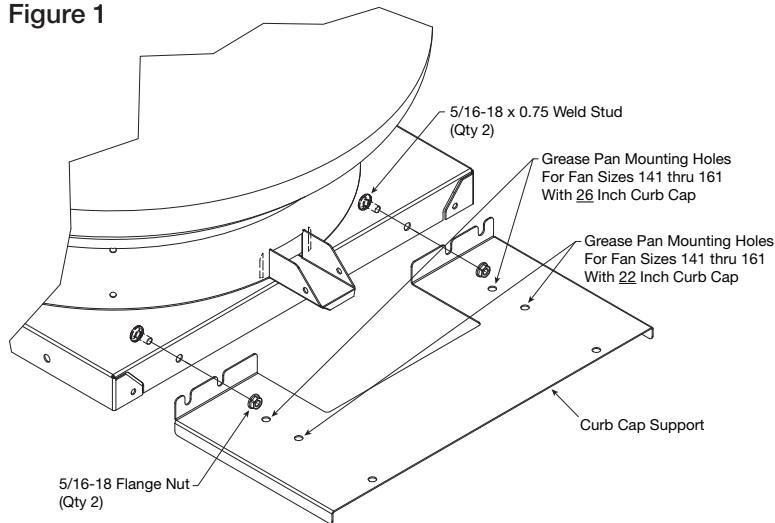
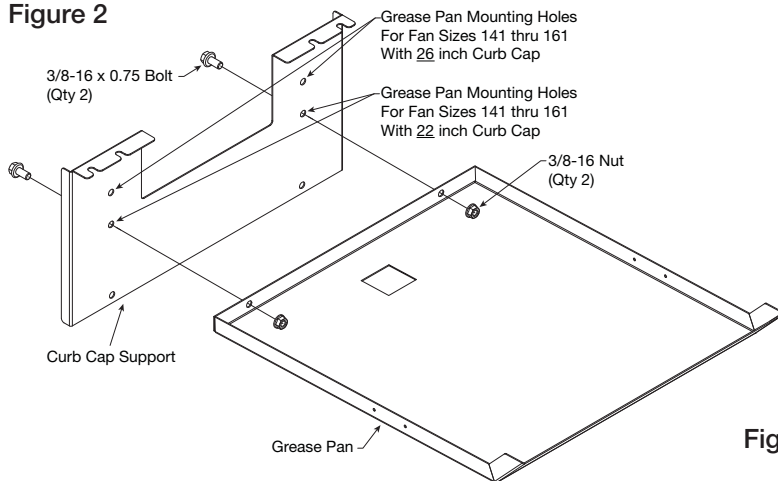

Figure 2



NOTE: If fan is connected to electrical source via rigid connection, a qualified electrician will need to change the rigid connection to a flexible connection long enough per local electrical codes to allow for fan movement.

1. It is recommended that the fan be placed on a flat, sturdy surface before proceeding with the installation of the grease pan kit. Once the grease pan kit has been installed, the fan can then be installed in the sidewall orientation on its appropriate curb.
2. Attach the curb cap support to the curb cap on the side of the grease trough using two 5/16-18 inch x 0.75 inch weld stud fasteners and two 5/16-18 inch flange nuts. See Figure 1.
3. Attach the grease pan to the curb cap support using two 3/8-16 inch x 0.75 inch fasteners and two 3/8-16 inch nuts. Grease pan mounting holes have been pre-punched and vary based on fan size.

NOTE: For fan sizes 141 thru 161, reference Figure 2. For all other fan sizes, reference Figure 3.

Figure 3

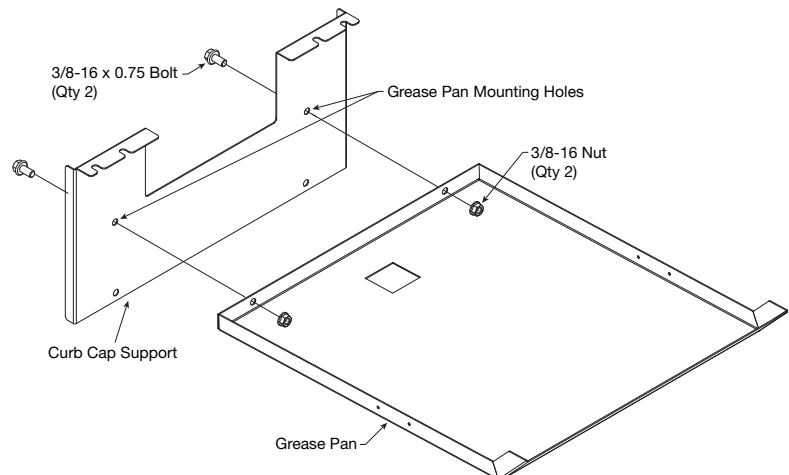

4. Locate the two windband support brackets. Loosely attach both brackets to the grease pan using two #12-11 x 0.625 inch sheet metal screws as seen in Figure 4. This will create less restraint for Step 5.
5. Remove two of the existing support bolts from the fan located on what will be the bottom side of the unit. Re-fasten the support bolts through the grease pan windband support brackets. See Figures 4 and 5.
6. Fully tighten the sheet metal screws attaching the grease pan to the windband support brackets.
7. Secure grease box to the curb cap support using what will be the bottom-most pre-punched set of holes. Use one 3/8-16 inch x 1 inch bolt, one 3/8 inch non-flanged nut, two 3/8 inch washers per side and one 3/8 inch flanged nut per side. See Figure 5. The non-flanged nut is intended to sit between the curb cap support and the grease box.

Figure 4

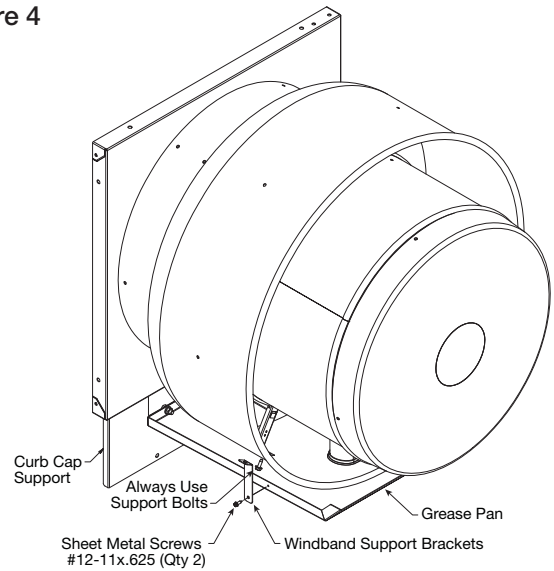
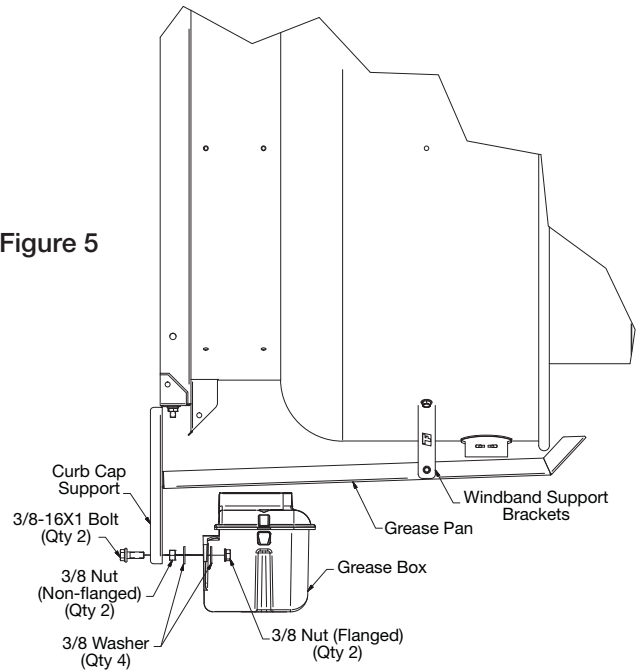

Figure 5



Our Commitment

As a result of our commitment to continuous improvement, Accurex reserves the right to change specifications without notice.

Product warranties can be found online at accurex.com, either on the specific product page or in the Warranty section of the website at Accurex.com/Resources/Warranty.



P.O. Box 410 Schofield, WI 54476
 Phone: 800.333.1400 • Fax: 715.241.6191
 Parts: 800.355.5354 • accurex.com