

Installation, Operation and Maintenance Manual

Please read and save these instructions for future reference. Read carefully before attempting to assemble, install, operate or maintain the product described. Protect yourself and others by observing all safety information. Failure to comply with these instructions will result in voiding of the product warranty and may result in personal injury and/or property damage.

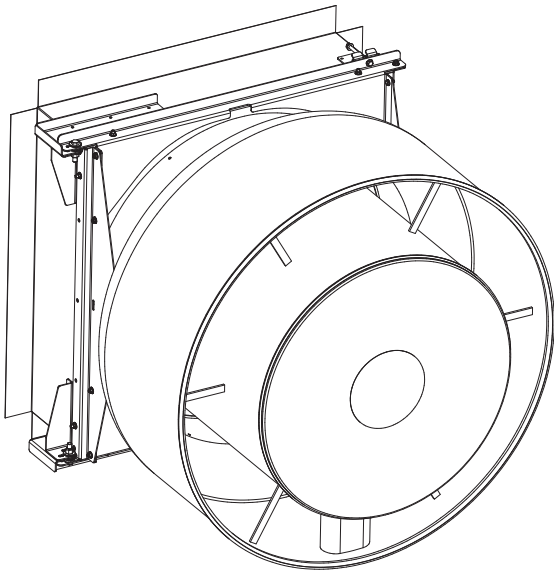

Included Fasteners		
Qty	Description	Part #
2	1/4"-20 x 1-1/2" L hex bolt	415517
2	1/4"-20 serrated flange nut	415455
8	5/16"-18 x 3/4" L weld stud	415160
8	5/16"-18 x 3/4" L serrated flange hex bolt*	415419
16	5/16"-18 serrated flange nut	415456
2	3/8"-16 x 3/4" L serrated flange hex bolt	415459
2	3/8"-16 x 5" L hex bolt*	417318
6	3/8"-16 serrated flange nut	415457
2	3/8"-16 nylon insert locknut*	415239
4	3/8" ID flat washer*	415081
2	1/2"-13 x 2" L hex bolt	415268
2	1/2"-13 nylon insert locknut	415269
10	1/2" ID flat washer	415380

*Not included in 180/200 sized kits

NOTE

If fan is connected to electrical source via rigid connection, a qualified electrician will need to change the rigid connection to a flexible connection long enough per local electrical codes to allow for fan movement.

WARNING

Disconnect power and observe proper lockout tagout procedures per OSHA Regulation, Title 29 Code of Federal Regulations Part 1910.147 & 1910.333.

Hinge Kit Assembly Components

Label	Description	Qty
A	Curb Cap Brace	2
B	Curb Cap Hinge	2
C	Hinge Plate	2
D	Hinge Brace*	2
E	Draw Latch	2

*Not included in 180/200 sized kits

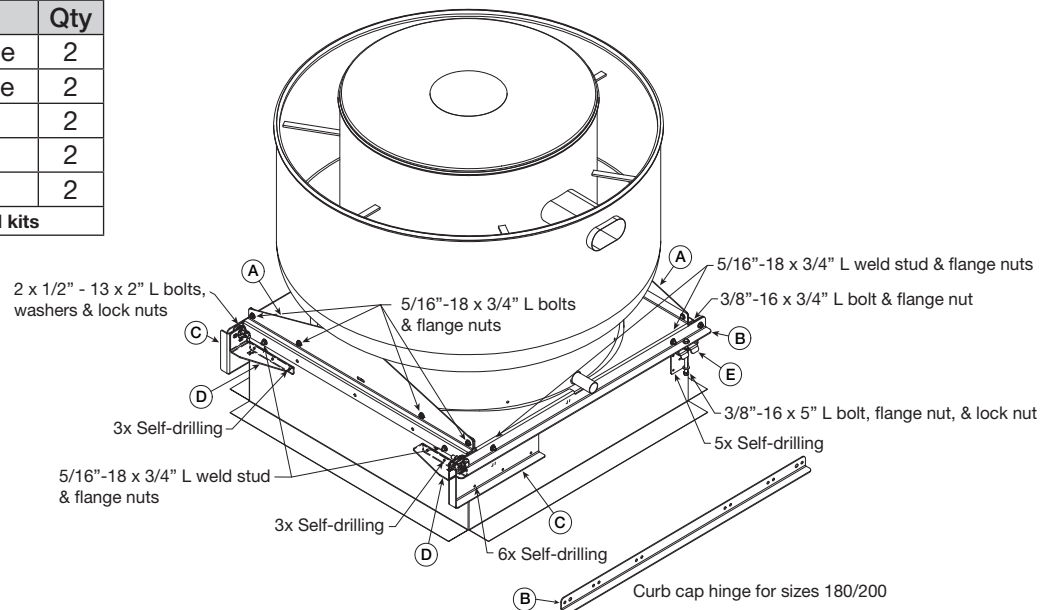

Recommendations for Installer

- Two 3/4" wrenches or hex sockets
- 9/16" wrench or hex socket
- 1/2" wrench or hex socket
- 7/16" wrench or hex socket
- #12 self-drilling screws (Qty: 28) and a bit to drive them (5/16")

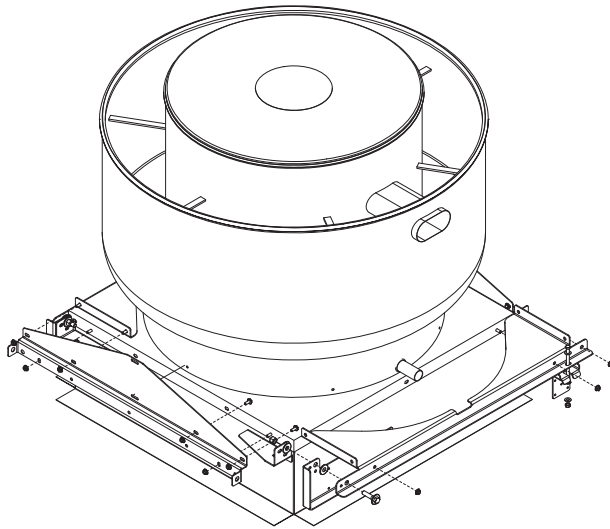

Installation

NOTE

It is recommended that sidewall hinging hardware is installed to the fan and curb in a vertical position before orienting in a sidewall position. This will ensure proper alignment.

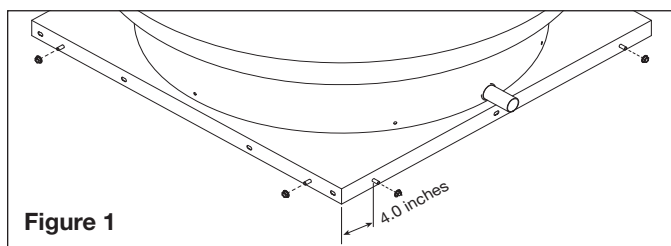

1. Before placing the unit on top of the curb and assembling this kit, install the 5/16"-18 X 3/4" L weld studs into the curb cap holes located about 4" from the corners, eight in total. See **Figure 1**.
2. Fasten a 5/16"-18 flange nut finger tight on each weld stud so the stud heads are flush to the inner surface of the curb cap. When all weld studs are installed, place the unit on top of the curb and remove the flange nuts.
3. Attach curb cap braces by removing two bolts from the fans vertical supports. Center brace over curb cap and attach with two vertical support bolts and along the curb cap brace, loosely install two flange nuts on the weld studs installed on Step 1. Repeat this step for other side of fan. See **Figure 2**.

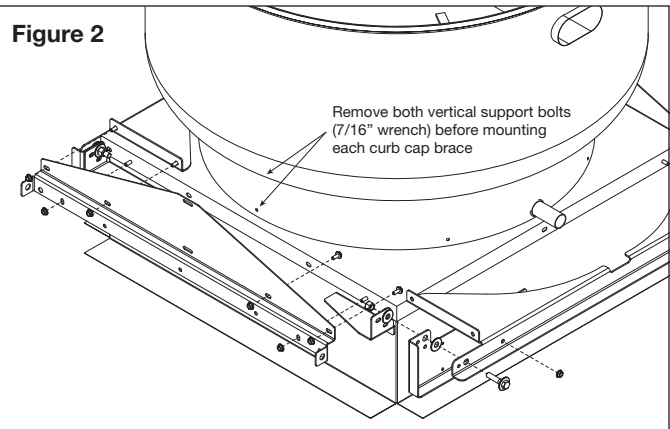

4. The "hinged side" of the curb cap hinge is the end which has two holes close together similar to the holes in the hinge plate. Opposite of the hinged side, align the hole of the curb cap hinge with the tab hole of the curb cap brace and loosely install 3/8-16 X 3/4" L bolt and flange nut. Repeat this step on the opposite side of the fan.

NOTE

For sidewall hinging applications, it is recommended that curbs have an undersizing of 1/2" for sizes 180/200 and 1" undersizing for 220/240/300 sizes.

5. Insert four 5/16"-18 X 3/4" L hex bolts into the holes on the upward flanges of the curb cap hinge and into the slots of the curb cap hinge and fasten flange nuts securely onto them. Repeat this step on the other side of the fan. These fasteners can be seen in **Figure 2**. This step does not pertain to sizes 180/200.
6. Before installing hinge components, ensure a majority of space between the curb and curb cap is on the side opposite from the breather tube and grease trough to account for sagging when hung.
7. On the side chosen for hinging, insert a 1/2"-13 x 2.5" L bolt with washer through the curb cap hinge, hinge plate, and curb cap brace. Install one washer between the hinge plate and curb cap brace.
8. Install an additional washer on the inside of the lower hinge bracket. See **Figure 3, Detail H**. When the 1/2" bolt appears to easily move in and out of its hole, secure the hinge plate to the curb using six self-drilling screws in the six 1/4" holes on the plate. Repeat this step for the other hinged side.

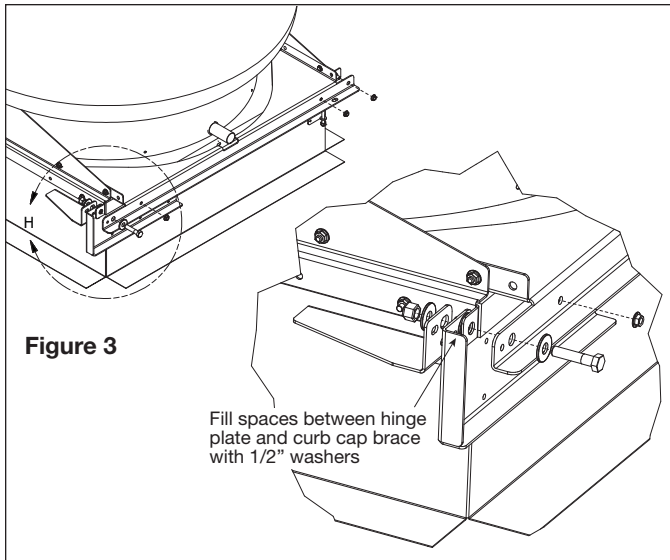

Figure 3

Fill spaces between hinge plate and curb cap brace with 1/2" washers

9. Using the 1/2"-13 hex bolt for alignment, line up the hinge brace so the locking holes allow for the 1/4"-20 x 1.5" L lock bolt to pass through and secure the hinge closed. Also ensure that the 1/2" bolt can easily be put through the curb cap hinge, hinge plate, curb cap brace, and hinge brace. Attach the hinge brace to curb using three self-drilling screws in the three 1/4" holes on the brace, see **Figure 4, Detail C**. Repeat this step for the other hinged side. The hinge brace is not included in sizes 180/200.

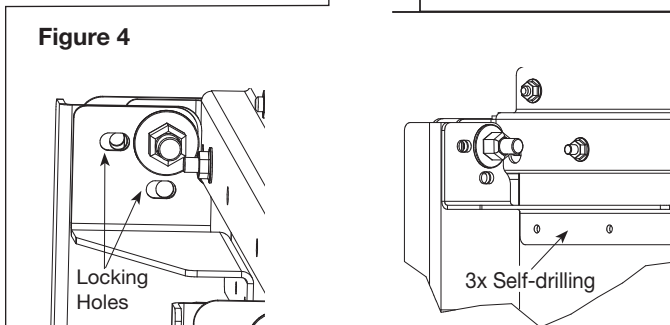
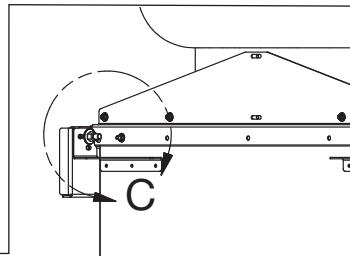

Figure 4

Locking Holes

3x Self-drilling

10. With all hinge components installed, place a 1/2" washer on the 1/2" bolt and secure the nylon lock nut. Be sure that it is not too tight to where it is difficult to open the hinge, this may also result in too much stress on hinge components. **Figure 5** shows a completed hinge.

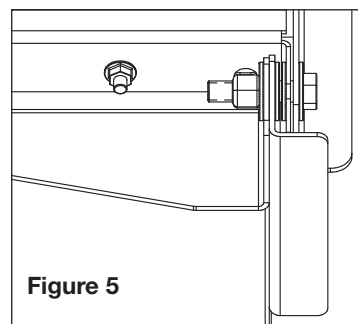

Figure 5

11. On the side which is not hinged, position the draw latch as shown in **Figure 6, Detail E** with the 3/8"-16 X 5" L hex bolt, 3/8" washer, and a flange nut. Draw the flange nut into the draw latch, the nut should be backwards, allowing the flange to act as a catch.
12. Bring the draw latch towards the curb cap hinge until the forward facing flanges are a little more than 1/8" away as shown in **Figure 6, Detail E**. Install four self-drilling screws into the 1/4" holes, remove the 3/8"-16 X 5" L bolt, and drive the last self-drilling screw into the remaining hole.
13. Repeat steps 11 and 12 on the other side of the unit.

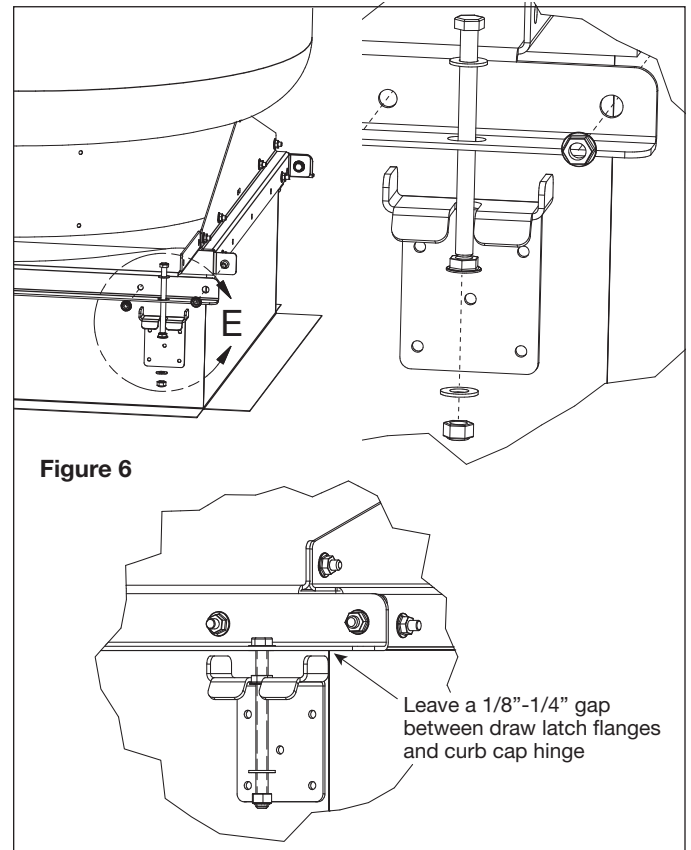
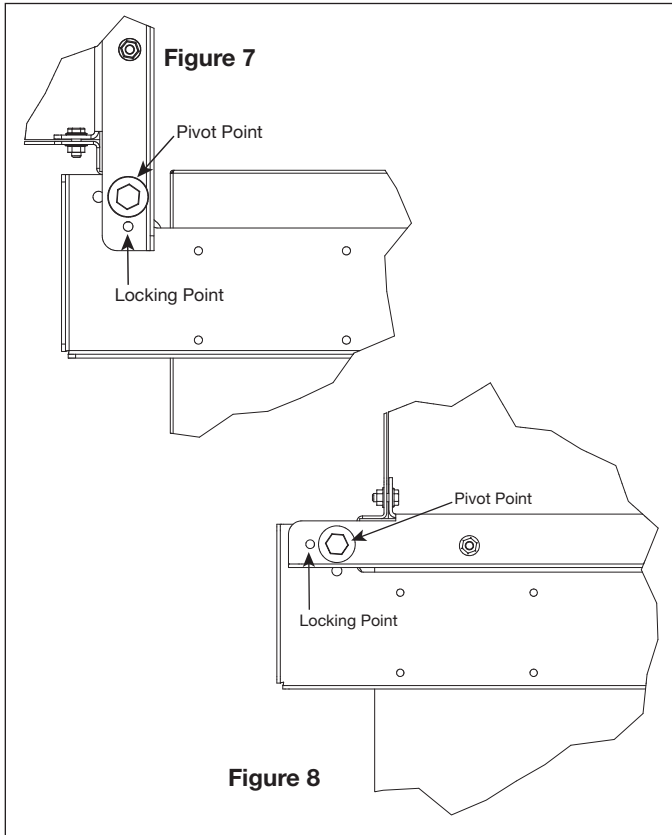

Figure 6

Leave a 1/8"-1/4" gap between draw latch flanges and curb cap hinge

14. Ensure all nuts/bolts are tightened. Remove the self-drilling screws from the hinge braces, hinge plates, and draw latches. Remove the fan from the curb.
15. Following curb manufacturer installation instructions, install the curb through the wall. Make sure the curb is installed in the correct orientation for left or right outward opening (not downward or upward), marking a wall face on the curb as "Top" or "Bottom" may help.
16. Orient the fan on the curb with the breather tube facing downward. Reinstall the self-drilling screws.

17. The draw latch and lock bolts/nuts in lock holes are the means for securing the hinged unit in a closed position. Reinstall the 3/8"-16 X 5" L bolt, washer, and reverse facing flange nut. Place a washer and 3/8"-16 nylon lock nut on the end of the 3/8"-16 X 5" L bolt as seen in **Figure 6, Detail E**, this will prevent the flange nut from being run off the end of the bolt and falling.
18. **Figures 7 and 8** show where the locking bolt should be utilized to lock the hinge kit either open or closed. Ensure that each bolt is securely fastened to the bracketry using the provided serrated flange nuts for the most effective results.



WARNING

When hinging fan open, lock bolts must be inserted in the lock-hole positions and secured to prevent sudden closure.

CAUTION

Forcible hinging of fan may result in damage to the fan curb cap. Take caution when hinging fan.

