

Installation, Operation and Maintenance Manual

Please read and save these instructions for future reference. Read carefully before attempting to assemble, install, operate or maintain the product described. Protect yourself and others by observing all safety information. Failure to comply with these instructions will result in voiding of the product warranty and may result in personal injury and/or property damage.

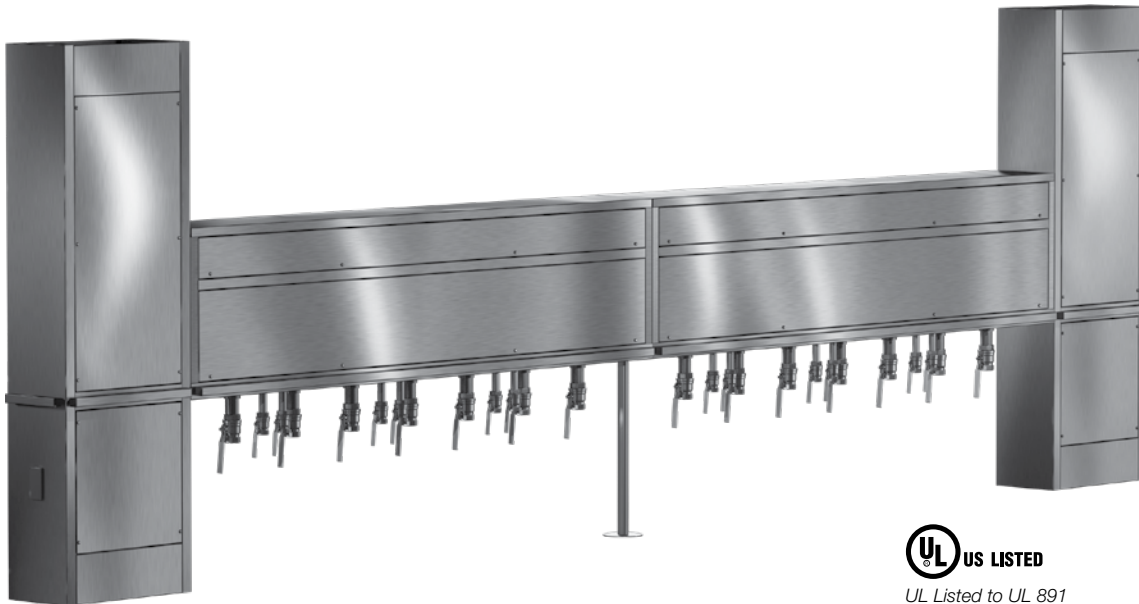

General Safety Information

Only qualified personnel should install and service this system. Personnel should have a clear understanding of these instructions and all applicable local and national building and fire codes.

DANGER

Always disconnect lock and tag power source before installing or servicing. Failure to disconnect power source can result in fire, shock or serious injury.

DANGER

Pour écarter les risques d'incendie, de choc électrique ou de blessure grave, veiller à toujours débrancher, verrouiller et étiqueter la source de courant avant l'installation ou l'entretien.

NOTE

Follow all local electrical and safety codes, as well as the National Electrical Code (NEC), and the latest edition of the National Fire Protection Agency Standard for Ventilation Control and Fire Protection of Commercial Cooking Operations (NFPA 96). Follow the Canadian Electrical Code and ULC-S650 if installing this product in Canada.

WARNING

Improper installation, adjustment, alteration, service or maintenance can cause property damage, injury or death. Read the installation, operating, and maintenance instructions thoroughly before installing or servicing this equipment.

AVERTISSEMENT

Les poses, réglages, modifications, entretiens et réparations incorrects peuvent provoquer des dégâts matériels, des blessures ou la mort. Bien lire les instructions de pose, d'utilisation et d'entretien avant l'installation ou l'entretien de ce matériel.

Table of Contents

Receiving, Handling and Storage	2
Product Overview	3
Unit Configuration	4
Option and Accessory Descriptions	5
Installation	
Uncrating	6
Mounting and Securing	6
Plumbing	7
Electrical	7-8
Main Incoming Service	8
Control Power	8
Fire System Integration	8
Hose Installation Instructions	9
Start-Up	
Testing	9
Fire Fuel Shut-Off, optional	10
Overcurrent Protection, optional	10
Operation	11
Troubleshooting	11
Our Commitment	12

Receiving

Upon receiving the equipment, check for both obvious and hidden damage. If damage is found, record all necessary information on the bill of lading and file a claim with the final carrier. If any items are missing, report shortages to your local representative to arrange for obtaining missing parts. Confirmation of shipment(s) must be limited to only items on the bill of lading. Any physical damage to the unit or missing parts found after acceptance is not the responsibility of the manufacturer.

Handling

Move the unit slowly and carefully using the forklift pockets on either end. Be sure to completely support the entire unit length when moving. Do not lay the crated unit on its side.

Storage

Units are protected against damaged during shipment. If the unit cannot be installed and operated immediately, precautions need to be taken to prevent deterioration of the unit during storage. The user assumes responsibility of the unit and accessories while in storage.

The ideal environment for storage of the UDS and accessories is indoors, above grade in a clean, dry atmosphere that is sealed from the elements. Store unit standing up; do not lay the unit on its side.



Product Overview

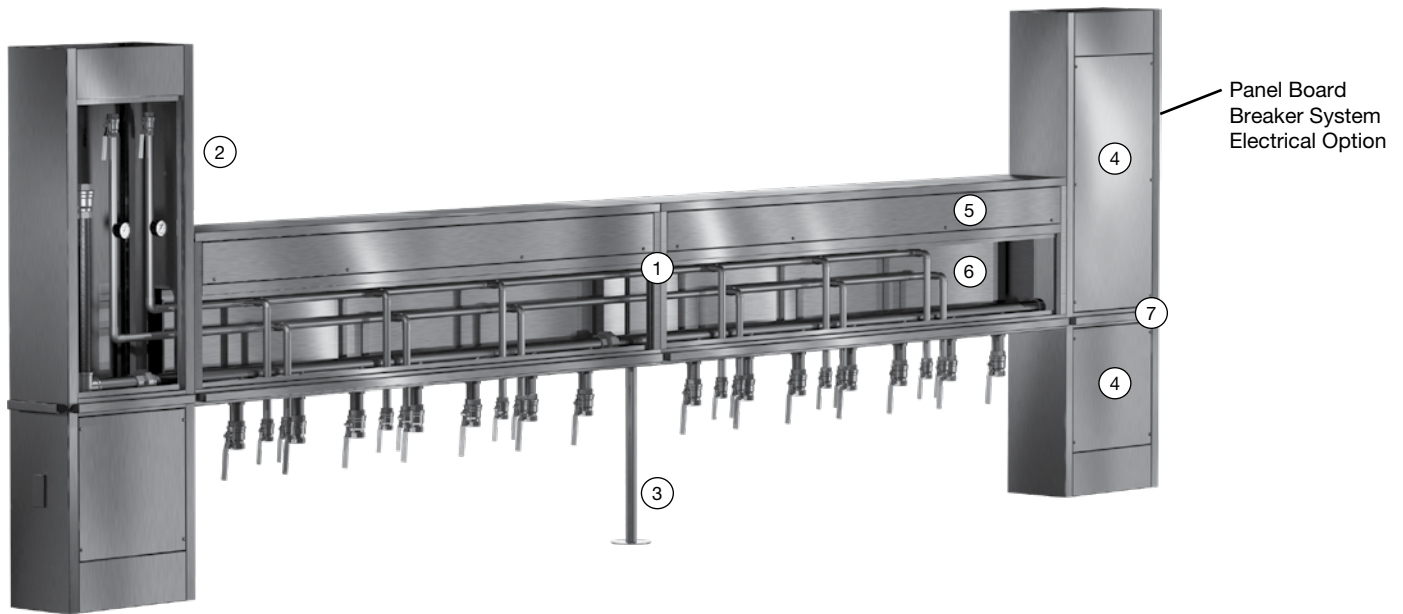

NOTE

Utility Distribution System, or UDS, are a highly configurable and customizable product. Some instances in this manual may make references to features which may or may not be present on your equipment. Please consult your submittal and electrical drawings which are also provided to determine which portions of this manual apply.

1. **Utility Chase** – Horizontal component that is connected between the two (2) vertical risers. This brings the utilities to the cooking equipment in a clean convenient way.
2. **Utility Riser** – Vertical components that house major utilities, control center, fire fuel shut-off, and field connections.
3. **Pedestal (optional)** – Supporting component for the chase under the field joint(s) at the chase when the UDS has reached a predetermined length.
4. **Access Panels** – Doors on the UDS that allow access for installation or maintenance.
5. **Electrical Section of Chase** – All electrical (typically wire bus or bus bar) is fed through this portion of the utility chase. This portion is intentionally closed off to the plumbing section of the utility chase. Electrical sections are accessible through removable panels.
6. **Plumbing Section of Chase** – All plumbing (typically includes gas, hot water, and cold water) is fed through this portion of the utility chase. This portion is intentionally closed off to the electrical section of the utility chase. Plumbing sections are accessible through removable panels.
7. **Bumper Strip** - Bump out strips mounted about waist-high on the UDS to prevent cooking equipment that is not fastened to the floor from hitting and damaging the UDS.

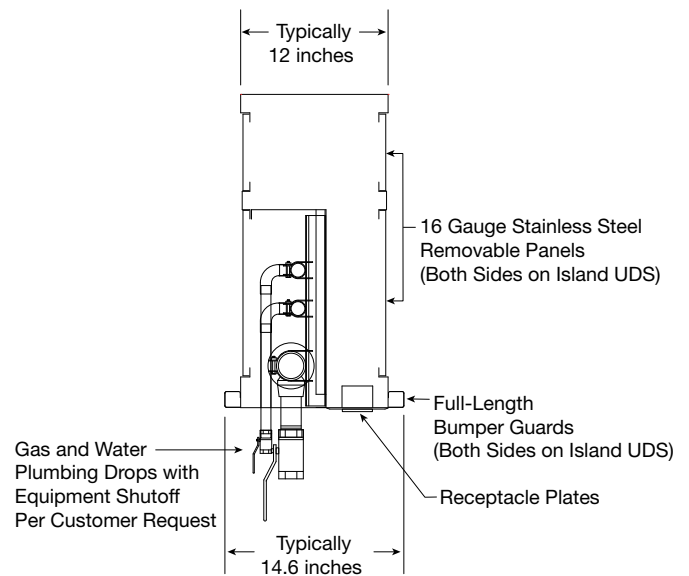

Typical Section View Through

Unit Configuration

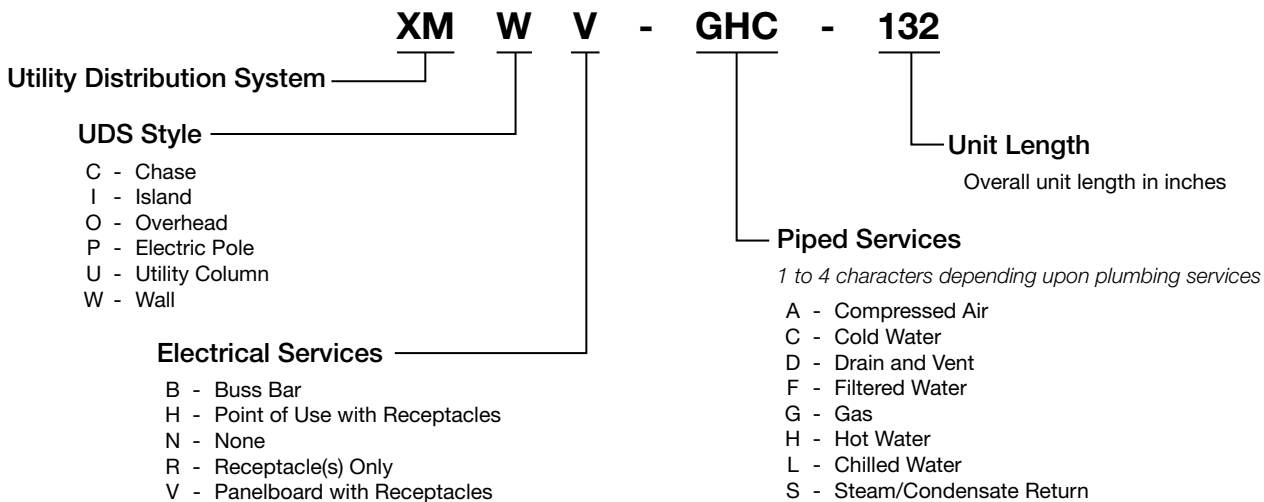

1. Manufacturer

- a. Model XM, Modular FlexConnect™ Utility Distribution System Series

2. Style

- a. (W) Wall – Mounted up against a wall with appliances on one side only; no bumper or electrical outlets on opposite side of utility chase (if provided with electrical service).
- b. (I) Island – Appliances on both sides; bumper and electrical outlets on both sides of utility chase (if provided with electrical service).

3. Electrical

- a. (V) Panelboard – Electrical service panelboard in either the right or left most riser. Typically, this includes a shunt trip or under-voltage main breaker and individual branch breaker(s) for each equipment receptacle. Breakers, wiring, and receptacles are all provided by the factory. 20A convenience outlets are provided on both left and right riser ends. Equipment receptacles are fastened in the specified location under the horizontal chase.
- b. (H) Point-of-Use – Incoming electrical service riser is located on the left or right most riser. Typically, this includes a shunt trip or under-voltage main breaker in the riser. Individual branch breakers for each piece of equipment are located in the horizontal chase directly inline with the equipment receptacle. 20A convenience outlets are provided on both left and right riser ends.
- c. (R) Receptacles Only – Unit shall include equipment receptacles fastened in the specified location under the horizontal chase. 20A convenience outlets are provided on both left and right riser ends. All wiring and/or conduit is provided by others in the field.

4. Gas

- a. (G) Gas Manifold – Either a single service through one riser, or a looped service through both risers is provided. Gas line is fed through the plumbing section of the utility chase by the factory, with gas drops every 12 inches. Typically, these are provided with quarter turn ball valve disconnects if used for specific appliances.

5. Water

- a. (H) Hot Water – Either 3/4 or 1 inch hot water manifold is fed through the plumbing section of the utility chase by the factory with drops every 24 inches. Typically, these are provided with quarter turn ball valve disconnects if used for specific appliances.
- b. (C) Cold Water – Either 3/4 or 1 inch cold water manifold is fed through the plumbing section of the utility chase by the factory with drops every 24 inches. Typically, these are provided with quarter turn ball valve disconnects if used for specific appliances.

6. Length

- a. Length – Total length of the UDS, including risers and utility chase by the factory.



Option and Accessory Descriptions

Chilled Water Line – Additional plumbing manifold to provide chilled water. This manifold will be insulated.

Compressed Air Line – Additional plumbing manifold to provide compressed air.

E-Stop Emergency Shut Off – Button provided to shut off electricity (and gas, depending on gas valve type) to the cooking equipment.

Equipment Cord Set – Combination cord and plug assembly that can be provided to wire into an appliance and be plugged into the UDS.

Equipment Hoses – Flexible hoses with steel mesh covers and quick disconnects for cooking equipment.

Fill Faucet – UDS mounted pot filler, typically used to fill commercial kettles with water.

Filler Panel between Risers – Stainless steel paneling to close off the area above and below the horizontal chase.

Filtered Cold Water – Option that includes water filter(s) within the UDS to filter contaminants out of the cold water supply. This may be required for certain appliances like combination ovens and steamers.

Gas Reset – Manual reset button and indicator light.

Gasketed Construction – Gasketing provided to cover all stainless steel edges within the UDS.

Ground Fault Protection – Receptacles and breakers with added electrical components to protect people from line to ground electrocution.

Hose Reel – A retractable hose reel to keep a pre-rinse spray valve assembly in a tight, contained space on the UDS.

Looped Gas – Configuration where gas manifold is fed from one riser, through the chase, and out the other riser. This provides more balanced gas supply, and is sometimes necessary with systems that need to deliver a large amount of gas for the cooking line up.

Main Breaker with Shunt Trip – Main breaker designed to trip during a fire or if the emergency stop button is pressed. This is standard with UDS configured with either point-of-use or panel board electrical service.

Main Breaker with Undervoltage Trip – Available upon special design request, this breaker is designed to trip upon a loss or dip in control voltage. This may be required per a local code or jurisdiction.

Make-Up Air through UDS – UDS designed with supply collars and perforation below the horizontal chase to provide dedicated make-up air for the kitchen hoods around the UDS.

Peak Top on Chase – Option to include a peaked chase top to help prevent grease from building up on the top of the chase.

Pin and Sleeve Receptacles and Plugs – Special type of twist-to-lock receptacle and plug that provides a durable, fused interlock in wet and corrosive environments.

Prison Package – For kitchens within a prison, it is important that the system is built without any components that could be removed and used as a weapon. For the UDS, this typically incorporates tamper proof fasteners, gasketed construction, and while-in-use receptacle covers.

Restraining Cables – Cable that attaches from the UDS to the movable appliance. This helps prevent appliances with gas and other plumbing connections from being pulled too far away and damaging the hoses. Length of the restraining cables need to be shorter than the length of the plumbing hoses.

Riser Extensions – Riser extensions paneling that extends from the top of the riser to the top of the hood or hood enclosure panels.

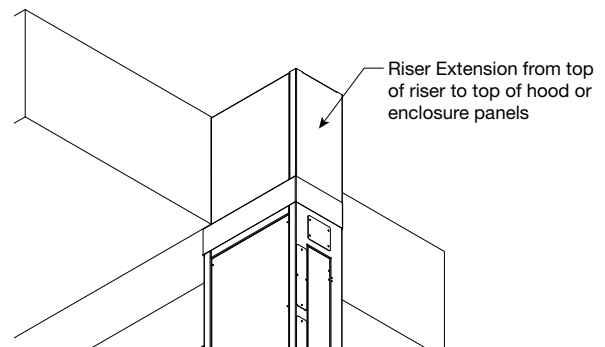

Slim Line Unit – UDS that is 8 inches wide or narrower, instead of the standard 12 inch width.

Status Lights – Status lights provided by each branch circuit breaker to indicate power.

Steam/Condensate Return – Additional plumbing manifold to provide steam/condensate return for steamers and other types of cooking equipment.

Super Swivel – Equipment hoses designed with a swivel adapter to prevent damage to the hose if equipment is moved frequently.

Twist Lock Receptacles – Receptacles designed to slip together then twist to lock into place. This keeps the plug and receptacle from pulling apart; also water-resistant.

UDS Mounted Hood Controls – Hood and fan controls, from fan switches to systems including motor starters or variable frequency drives can be built into the UDS.

Uninterruptable Power Supply (UPS) – Power supply for the control circuit within a UDS that is able to “ride through” any temporary building power outages.

NOTE

Other options are available. For more information, contact your local manufacturer’s representative.

Installation

Uncrating

Use caution when uncrating the UDS. Depending on the configuration, switches and indicator lights may be provided and protrude from the unit, use caution when moving the unit or moving equipment around the unit.

Mounting and Securing

1. Refer to drawings and equipment layout to determine the orientation of the UDS. Unit orientation is important as the unit is typically configured with drop locations specific to an initial set and order of appliances.
2. Gently lift the unit off of the pallet and position into place. If the UDS is broken into multiple sections, lift each section into place.
3. Remove all access panels on raceway, riser and pedestal to reveal internal plumbing, electrical, and internal flanges.
4. Once sections are in position, join field joints (if any) between sections by bolting internal flanges together and applying NSF approved silicone caulk (GE SCS-1009, or equivalent) over seams. Caulk is not provided.

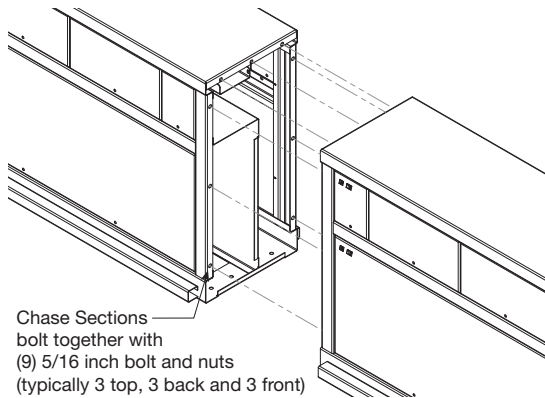

5. If applicable, drill holes through unit as shown on the drawing and secure properly to wall. This typically is required for systems that are not provided with risers.
6. If applicable, fasten risers to the floor.

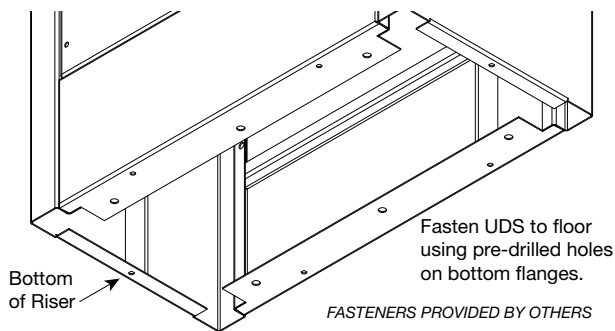

7. Complete all plumbing and electrical installation procedures. Reference drawing, and see pages 7 and 8.

8. If a kitchen hood or hoods is/are intended to be mounted on either side of the UDS, hang and level the hood(s) at this time. Make sure the hood is mounted at the specific height shown in the drawing provided.
9. Adjust riser collar(s) if supplied and as necessary by loosening nuts on weld studs inside riser collars, adjusting as necessary, and re-tightening nuts.

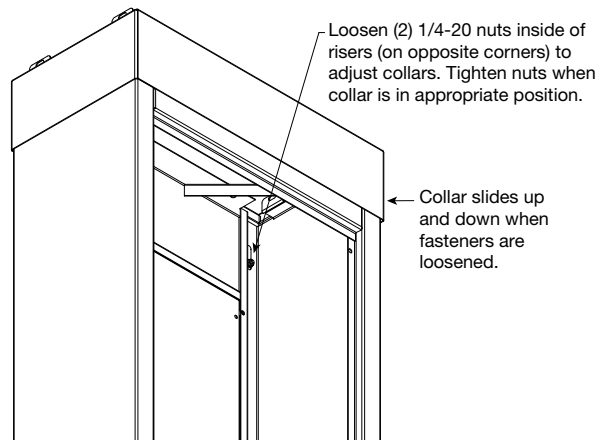

10. If applicable, make connections between the hood and hood controls to the utility distribution system. Once the fire system has been installed, tested, and armed, wire the fire system into the UDS as well.
11. Once all electrical connections have been completed on the hood, and all electrical and plumbing services have been connected to the UDS, install all filler panels and enclosure panels (if provided) between the hoods and above the hood and UDS.

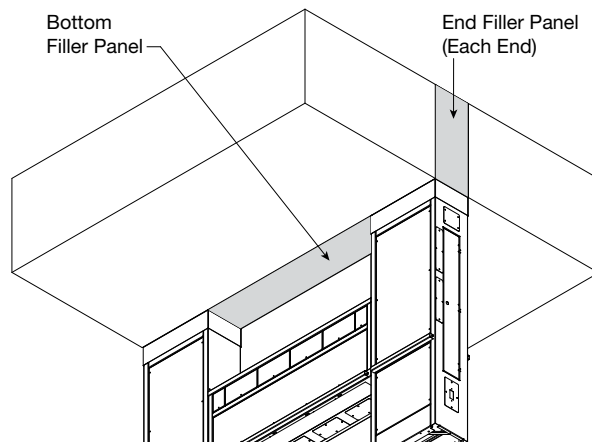

Plumbing

1. If system has field joint(s), plumbing must be connected at the joint(s) before attaching main service. Connect corresponding pipes by aligning unions and tightening securely.

NOTE

Do not force the threaded connections or pull sections together by tightening the plumbing fittings.

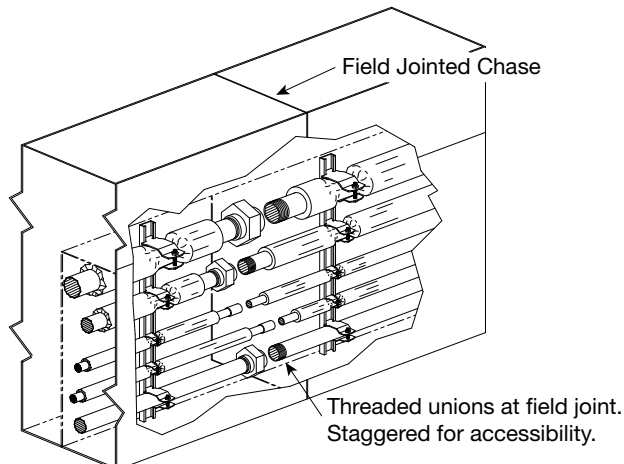

2. Connect all plumbing stub-ins to the main lines. Provide all necessary nipples, couplers, unions, etc. to make neat and proper connections.
3. Connect all hose assemblies (if provided) to the appropriate equipment as shown on the drawing. Provide all necessary L's and nipples to make neat and proper appearance. (Please see hose installation instructions on page 9).
4. During testing, check all plumbing for leaks and tighten as required.
5. Replace all access panels.

NOTE

This equipment is to be installed with adequate backflow protection to comply with federal, state or local codes having jurisdiction.

Electrical

1. If system has field joint(s), wiring must be interconnected at the joint(s) before attaching main service.
 - a. If provided with bus bar, connect the corresponding bus bars together with the brass bolts and nuts provided.
 - b. If provided with wire bus, connect number-matched wires from one section to the other using the corresponding terminal blocks provided.

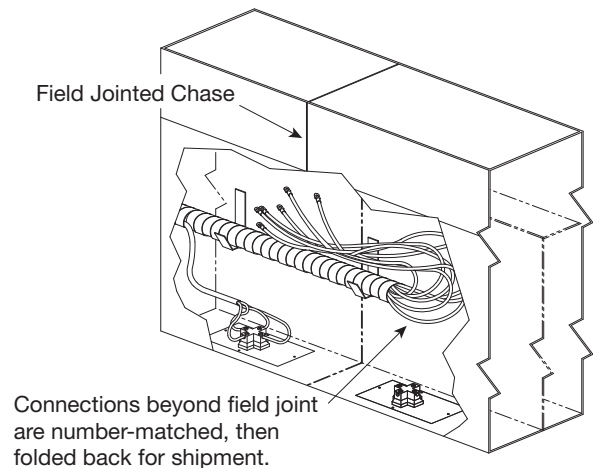

2. Connect the electrical service(s) to the system as follows:
 - a. Attach main service wires to the corresponding terminals on the main breaker and neutral bar.
 - b. Connect all control wiring as shown in the electrical drawing provided with the unit. Additional information is shown on page 8.
 - c. Check and tighten connections if necessary.
 - d. Connect all cord assemblies to the appropriate equipment as shown on submittal drawing. Cut cord assemblies if necessary to make a neat appearance.
 - e. Test the electrical systems for proper operation.
 - f. Replace all access panels.

NOTE

All field wiring of electrical equipment must be done to meet all NEC and local electrical codes.

The extent of field wiring required will depend on the configuration of the UDS. A few options are broken out in the next portion of this manual. Reference the UDS electrical drawings provided with the unit for more specific wiring details.

Main Incoming Service

UDS appliance power is typically provided from 120/208/3 and/or 460/3 60Hz power from the building directly to the main breaker(s) within the electrical riser from above. Service size should be shown on the UDS drawing.

- 120/208V/3PH to main breaker, neutral lug, and grounding bar
- 460V/3PH to main breaker and grounding bar

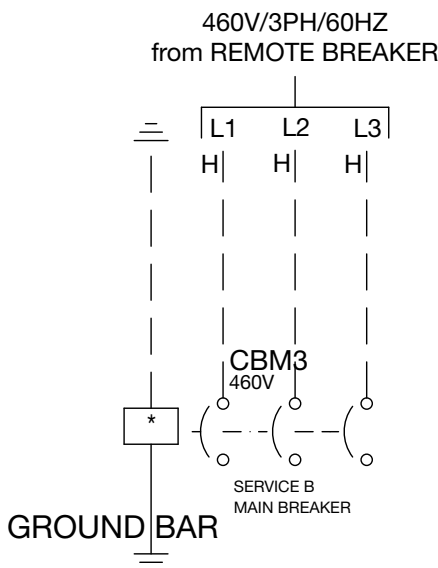
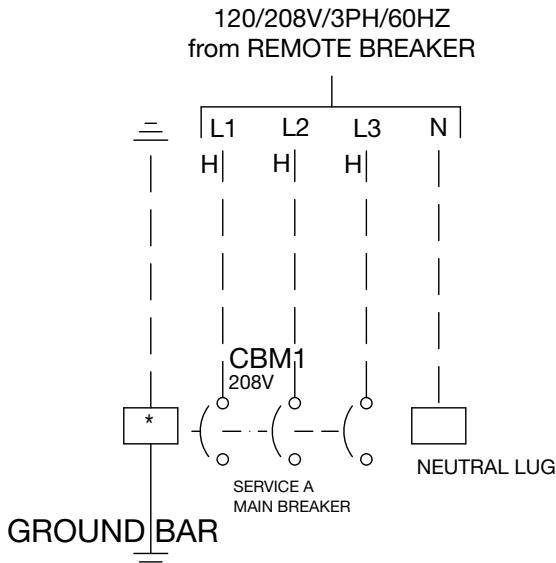

Control Power

The UDS needs a power source to operate all control components. This source must come from a separate, non-shunted breaker from the building; the power must remain constant, even during the event of a fire.

- 120VAC, 10 amp circuit to terminals H and N

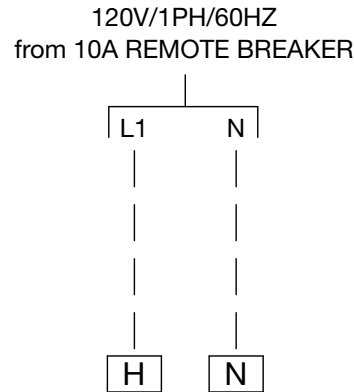

Fire System Integration

A dedicated fire system microswitch or dry SPDT set of fire contacts needs to be wired to the UDS. During a fire, this will shut off fuel to the cooking equipment per NFPA 96.

- Common on microswitch to terminal C1
- Normally-closed to terminal NC1
- Normally-open to terminal NO1

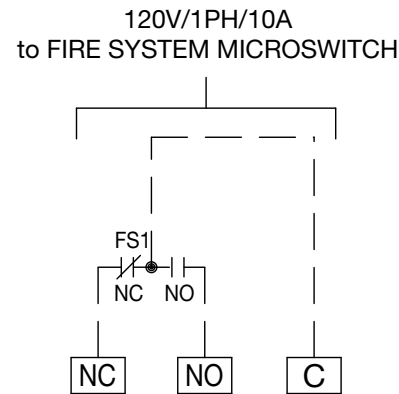

Hose Installation Instructions

1. Check sizes and quantity of hose assemblies as shown on the drawing.
2. Make sure all plumbing 1/4 turn ball valves are in the off position. When the handle is in-line with the pipe, the valve is in the “on” position. When the handle is at a right angle to the pipe, it is in the “off” position.
3. Connect all hose assemblies to the appropriate equipment as shown on the drawing. Provide and install necessary plumbing fittings to present a neat appearance and to ensure that the hose assemblies do not touch floor. To connect hoses to quick disconnects, pull back sleeve, and push plug into socket. To disconnect, pull back sleeve, unlocking the coupling.



4. To ensure proper installation and minimal wear of hoses, follow the examples shown below:

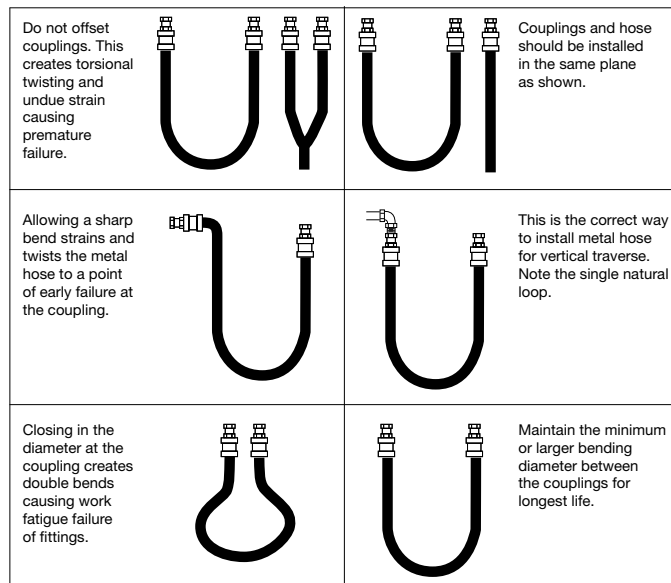

Start-Up

Testing

1. After installation has been completed, including plumbing and electrical connections, replace all access panels in the electrical chase.
2. Make sure all breakers (including the main) are in the off position.
3. Make sure all service and appliance ball valves are closed.
4. Slowly open the cold water main supply ball valve (if provided). Check for leaks between the main ball valve and appliance ball valves. Once check is complete, close the main supply valve.
5. Repeat step 4 for hot water and steam valves (if provided), as well as any other plumbing valves except for gas (if provided).
6. Turn on main service circuit breakers.
7. Turn on each branch breaker and check the status lights (if provided) and GFCI receptacles connected to each breaker. Continue with all branch breakers.
8. Slowly open the gas main supply ball valve until fully open (if provided). If equipped with an electric gas valve, press the RESET button on the fire fuel shut off panel to allow gas to flow to the appliance ball valves. Check for leaks.
9. At this point, hook up all equipment (plug and cordsets, plumbing hoses). Refer to Hose Installation Instructions found on this page.
10. Open all appliance ball valves.
11. With everything on, test appliances for proper operation and look for any leaks.
12. If provided, test fire fuel shut-off (see page 10 for fire fuel shut off operation).

Fire Fuel Shut-Off (optional)

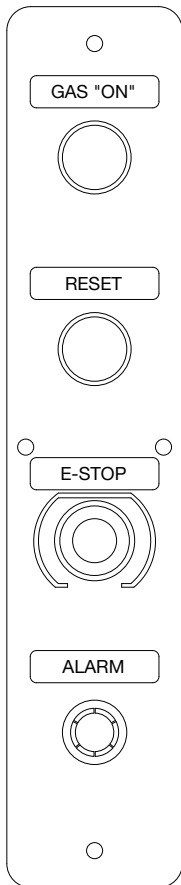

Sequence of Operation

1. Electricity

Actuation of the fire system will trip all circuit breakers equipped with the fire-fuel shut off feature and de-energize the corresponding outlets. Typically, this occurs only on the main service shunt trip breaker(s) in the UDS electrical riser. If equipped, the audible alarm in the UDS will sound. After the fire system is returned to the cocked (armed) position under normal operating conditions, these circuit breakers will remain de-energized until manually reset.

2. Gas

Actuation of the fire system will stop all gas flow to the gas operated equipment. If equipped, the audible alarm in the UDS will sound. If the UDS is supplied with a mechanical gas valve, after the fire system is returned to the cocked (armed) position under normal operating conditions, gas will flow to all gas operated equipment. If the UDS is supplied with an electric gas valve,

after the fire system is returned to the cocked (armed) position under normal operating conditions, the button marked gas reset must be pressed to allow gas to flow to all gas operated equipment. A "GAS ON" pilot light will illuminate when gas is allowed to flow to all gas operated equipment.

IMPORTANT

After the gas has been reset, all pilot lights must be re-lit. Failing to re-light pilots will cause gas to flow into the kitchen.

Emergency Stop

Depressing the emergency stop switch will trip the main shunt trip breaker(s), and stop all gas flow to the gas operated equipment (if provided with an electric gas valve). To reset, pull this emergency stop switch out, then press the RESET button. The main circuit breaker must then be reset (turned to the OFF, then to the ON position) to re-energize the outlets.

IMPORTANT

After the gas has been reset, all pilot lights must be re-lit. Failing to re-light pilots will cause gas to flow into the kitchen.

Overcurrent Protection (optional)

Testing

1. Turn all individual equipment controls to the OFF position before attempting to connect or disconnect any cord and plug assembly. After the cord and plug assembly is connected, equipment may be turned ON.
2. When the circuit breaker is in the OFF position, the receptacle operation indicator light will not be illuminated. To energize the outlet, turn the circuit breaker to the ON position. The receptacle operation indicator light will turn ON.
3. To test the connection plate, turn the circuit breaker to the ON position and press the PUSH TO TEST button. The circuit breaker will automatically turn to the OFF position and the outlet will be de-energized.
4. Turn the circuit breaker back to the ON position and the outlet will be energized. The equipment is now ready for operation.

Current Sensor Adjustment

NOTE

Ground fault nuisance tripping may occur on certain pieces of equipment. If this situation occurs, follow these steps

1. Turn off ALL main services to raceway.
2. Carefully remove the screws securing the access panel.
3. Locate the ground fault sensing relay and adjust the potentiometer slightly clockwise.
4. Carefully replace the access panel and tighten securely.
5. Test the circuit breaker and appliance.

NOTE

If intermittent tripping continues, contact the factory for further instruction.



Operation

Under normal operation, appliances should remain powered unless:

- a. a fire or fire test occurs, or
- b. the emergency stop is pressed.

If provided with fan or light controls, buttons to control the lights and/or fans will be provided. Pressing these buttons will operate hood lights and fans. For more information, reference the drawings provided with the UDS.

Troubleshooting

Problem: Main breaker trips.

Has the main breaker been reset properly?	Turn the main breaker completely off, then into the on position.
Is the breaker too small?	Check the breaker size and service load and consult the UDS drawings.
Faulty wiring?	Check the wiring and fire microswitch wiring.
Faulty breaker	Replace main circuit breaker

Problem: Branch breaker trips.

Has the branch breaker been reset properly?	Turn the branch breaker completely off, then into the on position.
Current sensor needs adjustment.	If UDS is supplied with over current protection, the sensor in the raceway may need adjustment. See page 10 for instruction on adjusting current sensor.

Problem: Main breaker will not reset.

Fire system in fire position	Fire system must be reset.
Fire system microswitch is not connected	Connect fire microswitch to UDS. See UDS drawings for details.

Problem: Electric gas valve will not open.

Is the system in fire condition?	Check fire microswitch connections and fire system status.
----------------------------------	--

Problem: Water and/or gas is not working.

Are the manual shut off valves in the service risers on?	Check valves to see if they are on.
Are the appliance quick disconnects attached?	Check quick disconnects behind appliances for proper installation.

Our Commitment

As a result of our commitment to continuous improvement, Accurex reserves the right to change specifications without notice.

Product warranties can be found online at accurex.com, either on the specific product page or in the Warranty section of the website at Accurex.com/Resources/Warranty.



P.O. Box 410 Schofield, WI 54476
Phone: 800.333.1400 • Fax: 715.241.6191
Parts: 800.355.5354 • accurex.com